

SIE ERREICHEN UNS
UNTER DER SERVICE-HOTLINE
☎ +49 8178 - 932 932

FÜR TÜREN

INDIVIDUELL
ANPASSBAR



Eine aktuelle Version dieser Anleitung finden Sie auf/
*You can find a current version of these instructions at the following address/
Vous pouvez trouver une version actuelle de ces instructions à l'adresse suivante/
Puede encontrar una versión actualizada de estas instrucciones en la siguiente dirección/
Potete trovare una versione aggiornata di queste istruzioni al seguente indirizzo/
Een actuele versie van deze instructies is te vinden op het volgende adres/
Aktualną wersję tej instrukcji można znaleźć pod następującym adresem:*



<http://www.jarolift.de/bedienungsanleitungen.html/>

INSEKTENSCHUTZ SCHIEBETÜR

Auf Mass

ORIGINAL MONTAGEANLEITUNG

JAROLIFT®™



Übersicht	3
Verpackungsinhalt	4
Verpackungsinhalt einfache Tür	4
Verpackungsinhalt Doppeltür	5
Empfohlenes Werkzeug	6
Montage	7
Kontaktinformationen	24



einfache Tür - Montage A

Variante 1

Montagerahmen inkl. seitlicher Führungsschienen (links und rechts)

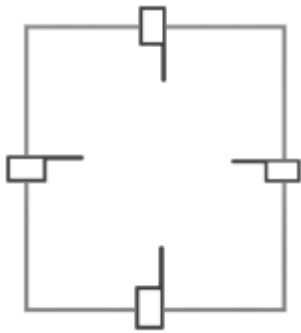
**Variante 2**

Montagerahmen ohne seitliche Führungsschienen

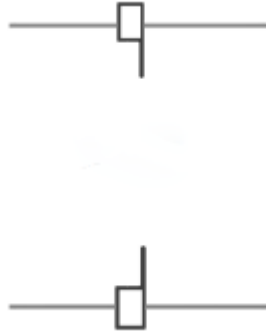

Doppeltür - Montage B

Variante 1

Montagerahmen inkl. seitlicher Führungsschienen (links und rechts)

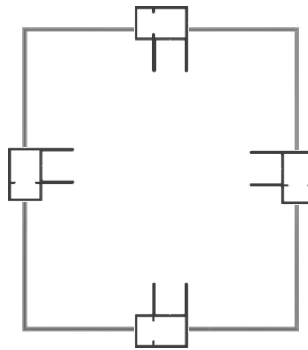
**Variante 2**

Montagerahmen ohne seitliche Führungsschienen

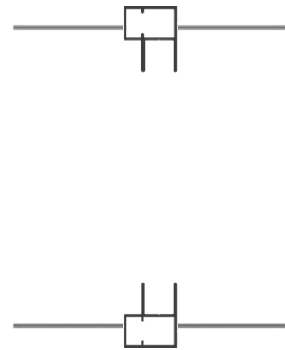

Bitte wählen Sie Schrauben und Dübel für die Befestigung des Montagerahmens auf Ihrem Türrahmen in Abhängigkeit vom jeweiligen Montageuntergrund. Schrauben und Dübel sind daher nicht im Lieferumfang enthalten.



VERPACKUNGSINHALT EINFACHE TÜR

FÜR DIE SCHIEBETÜR

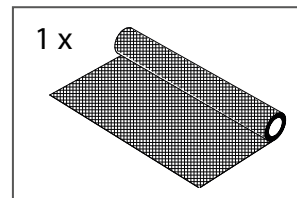
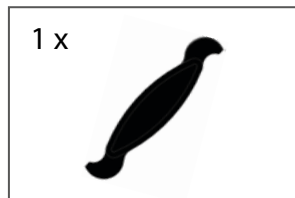
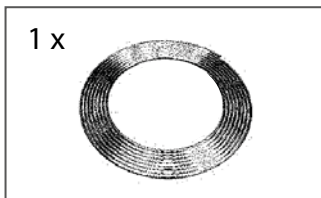
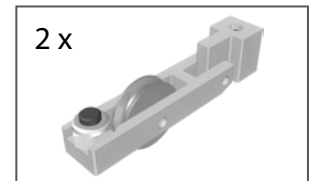
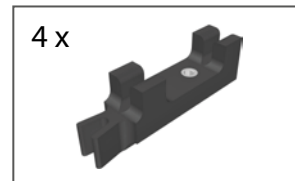
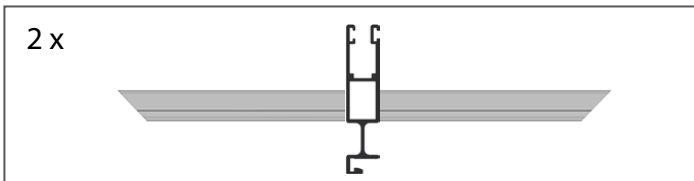
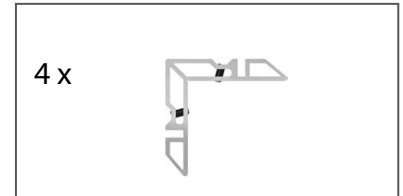
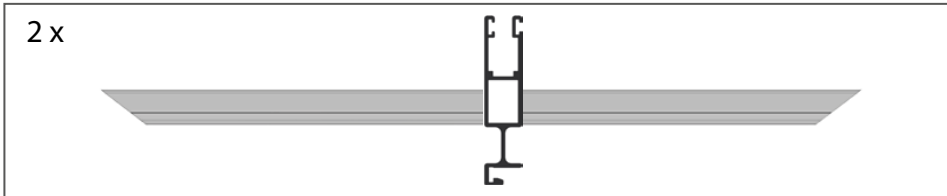

FÜR DEN MONTAGERAHMEN

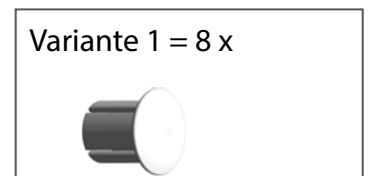
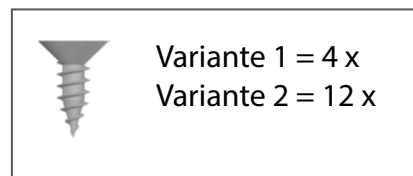
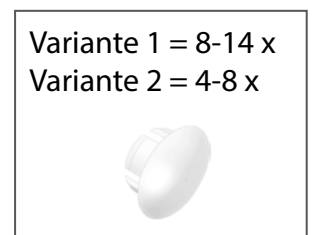
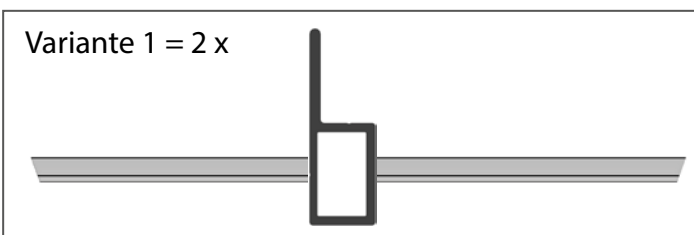
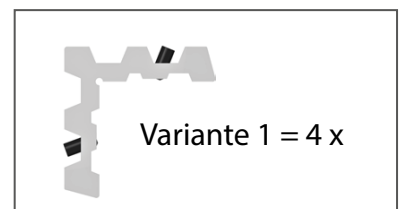
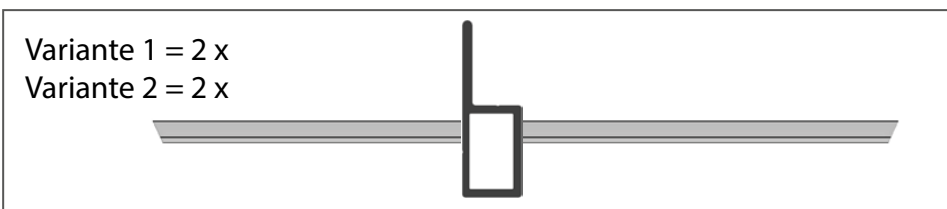

VERPACKUNGSGEHALT DOPPELTÜR

FÜR DIE SCHIEBETÜR

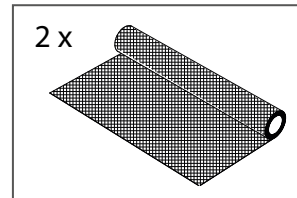
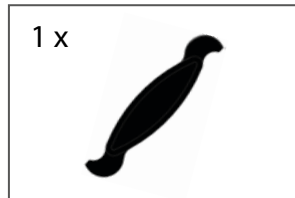
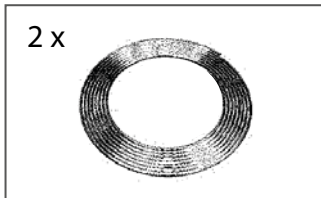
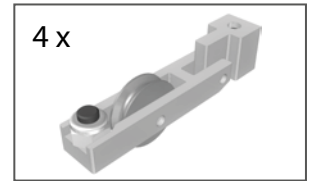
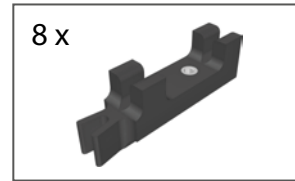
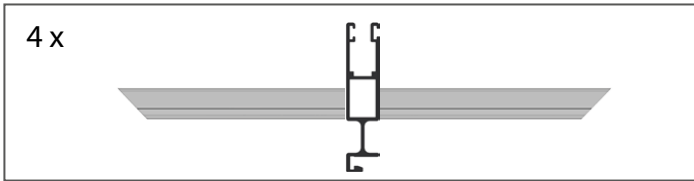
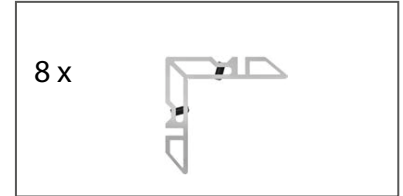
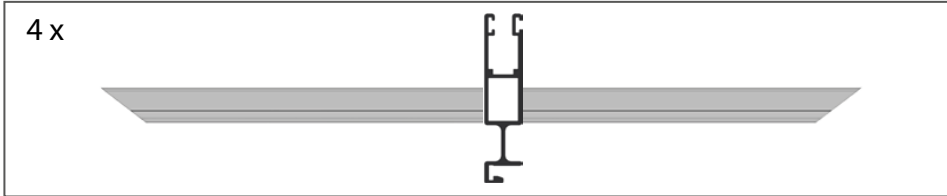

FÜR DEN MONTAGERAHMEN

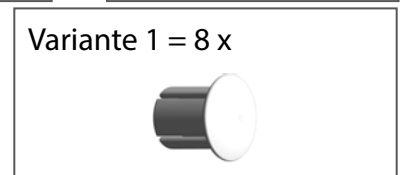
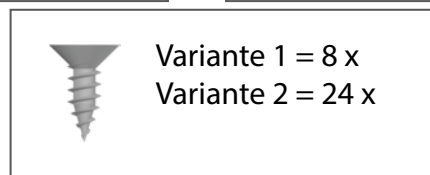
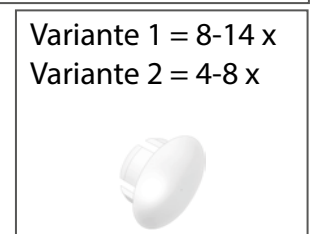
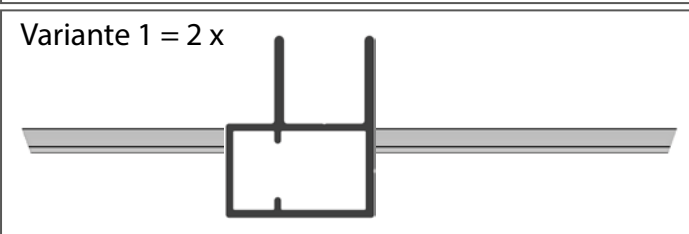
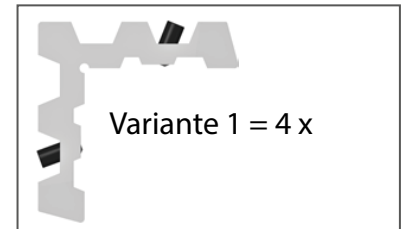
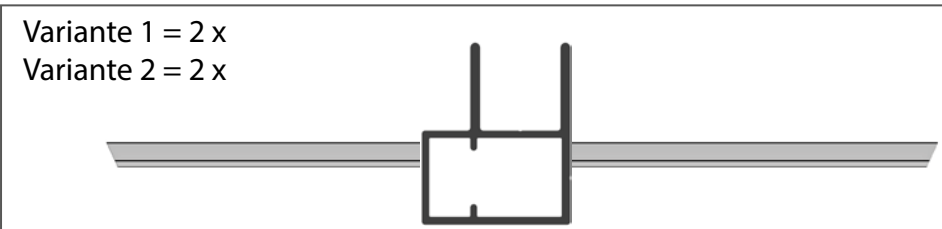



EMPFOHLENES WERKZEUG

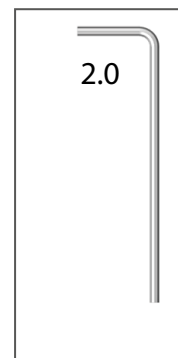
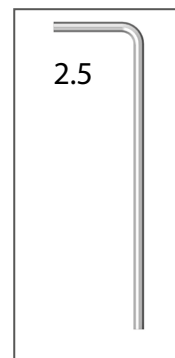
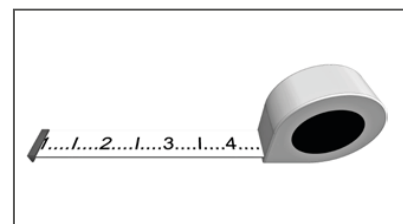
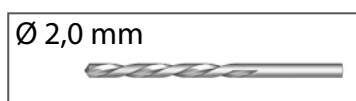
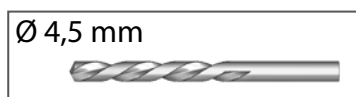
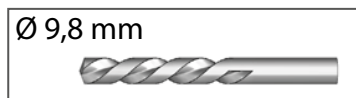
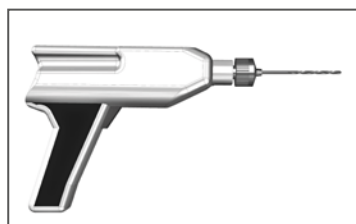
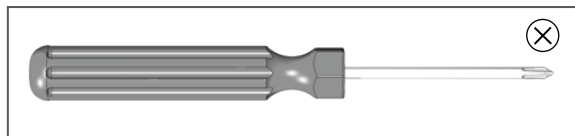
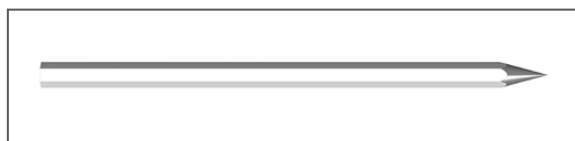

VORBEREITUNG DES MONTAGERAHMENS

MONTAGE A - EINFACHE TÜR - VARIANTE 1

1

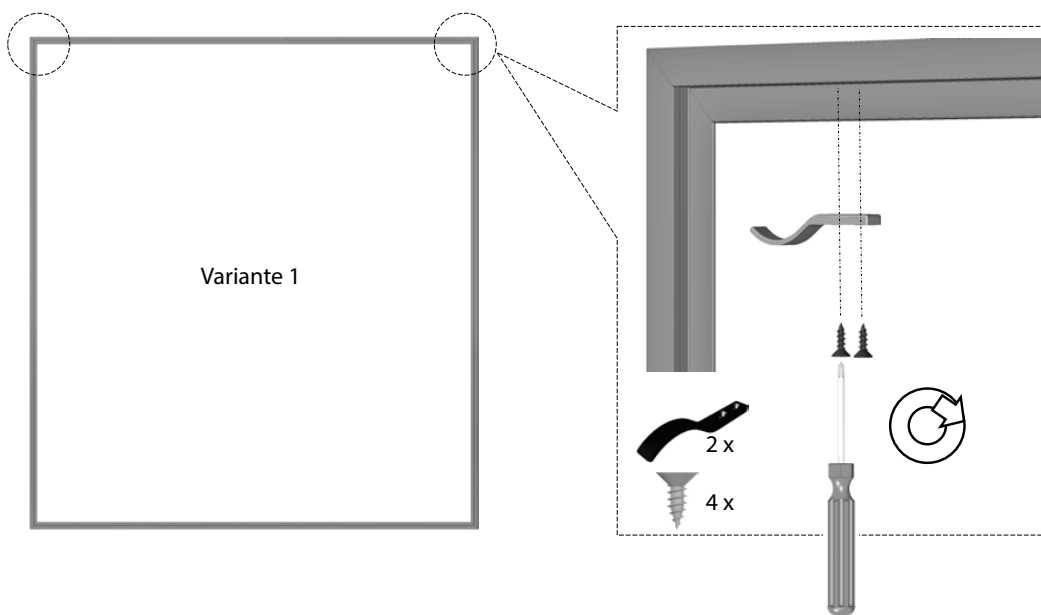
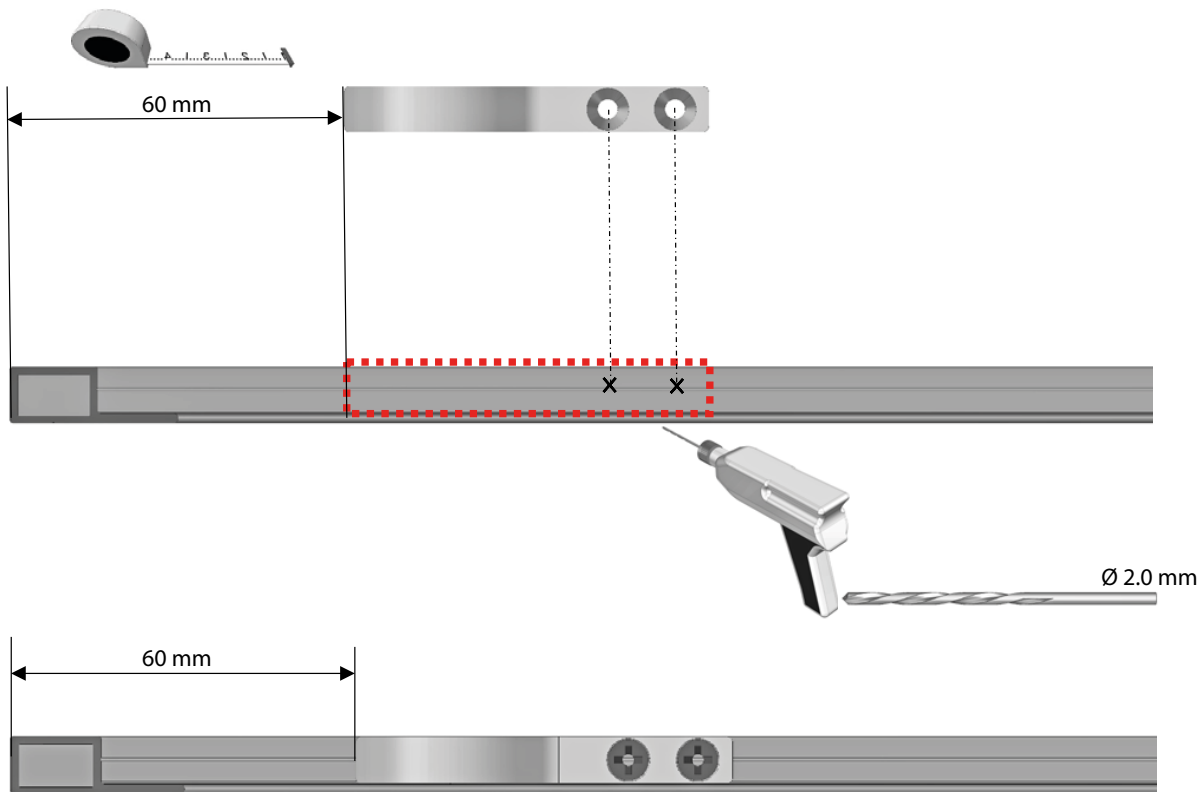



VORBEREITUNG DES MONTAGERAHMENS

MONTAGE A - EINFACHE TÜR - VARIANTE 2

1

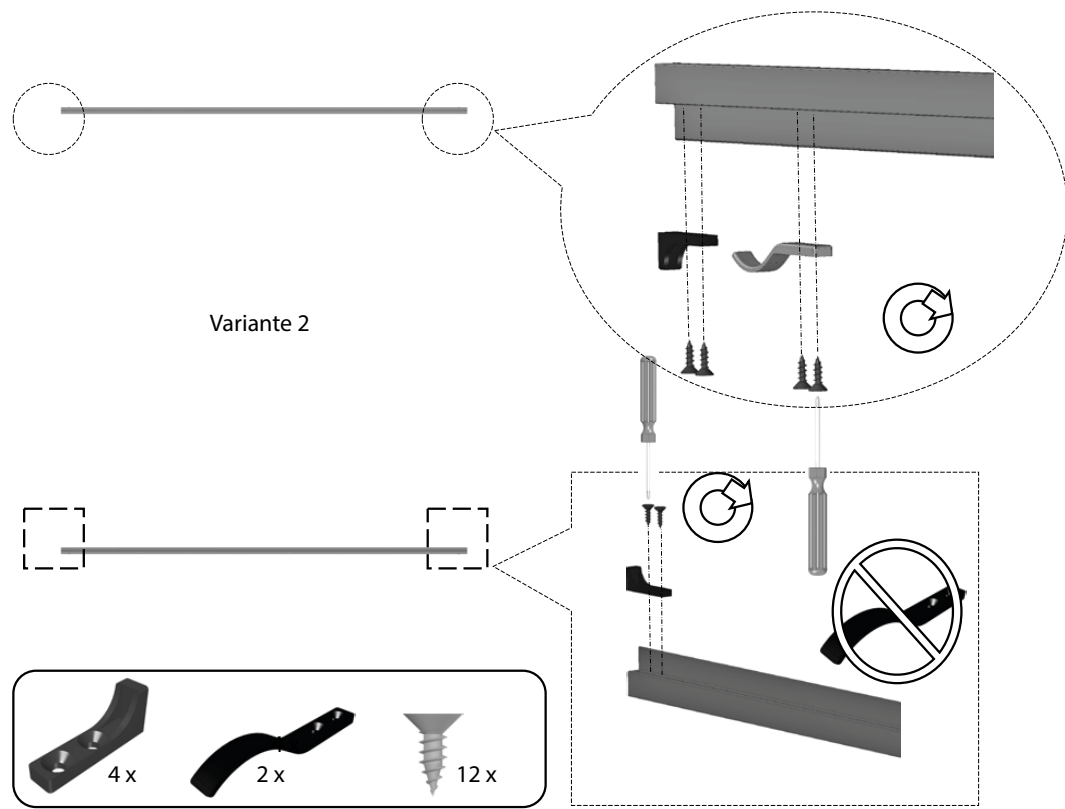
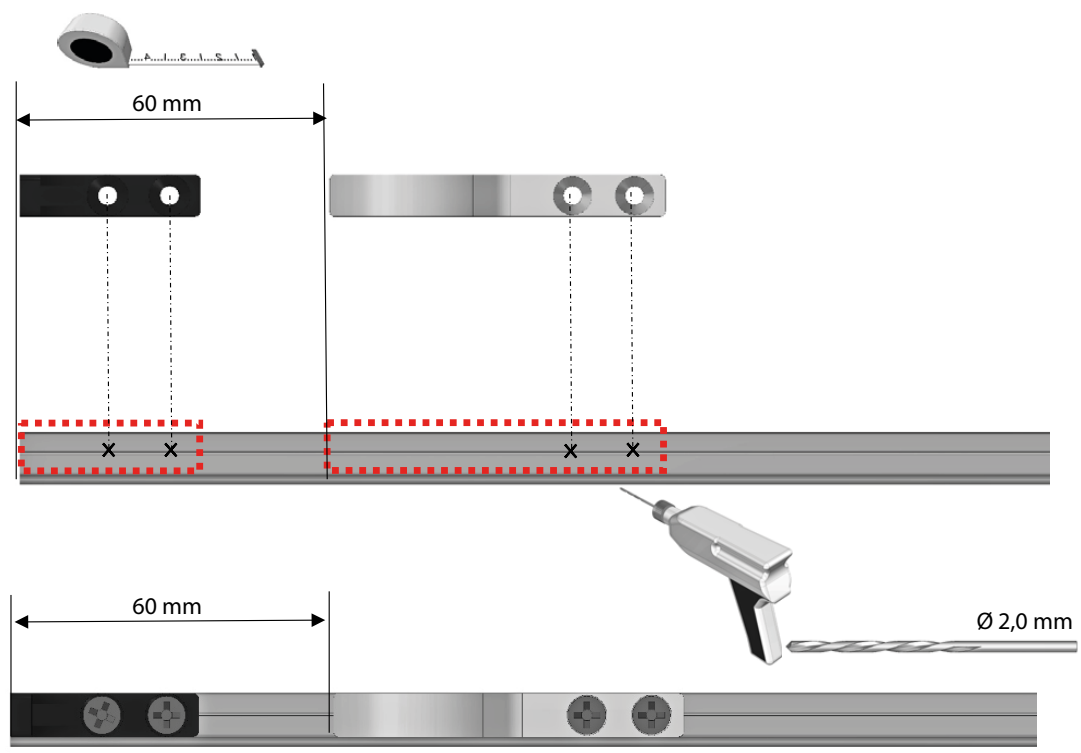

HERSTELLEN DER MONTAGELÖCHER IM MONTAGERAHMEN

MONTAGE A - EINFACHE TÜR - VARIANTE 1 UND 2

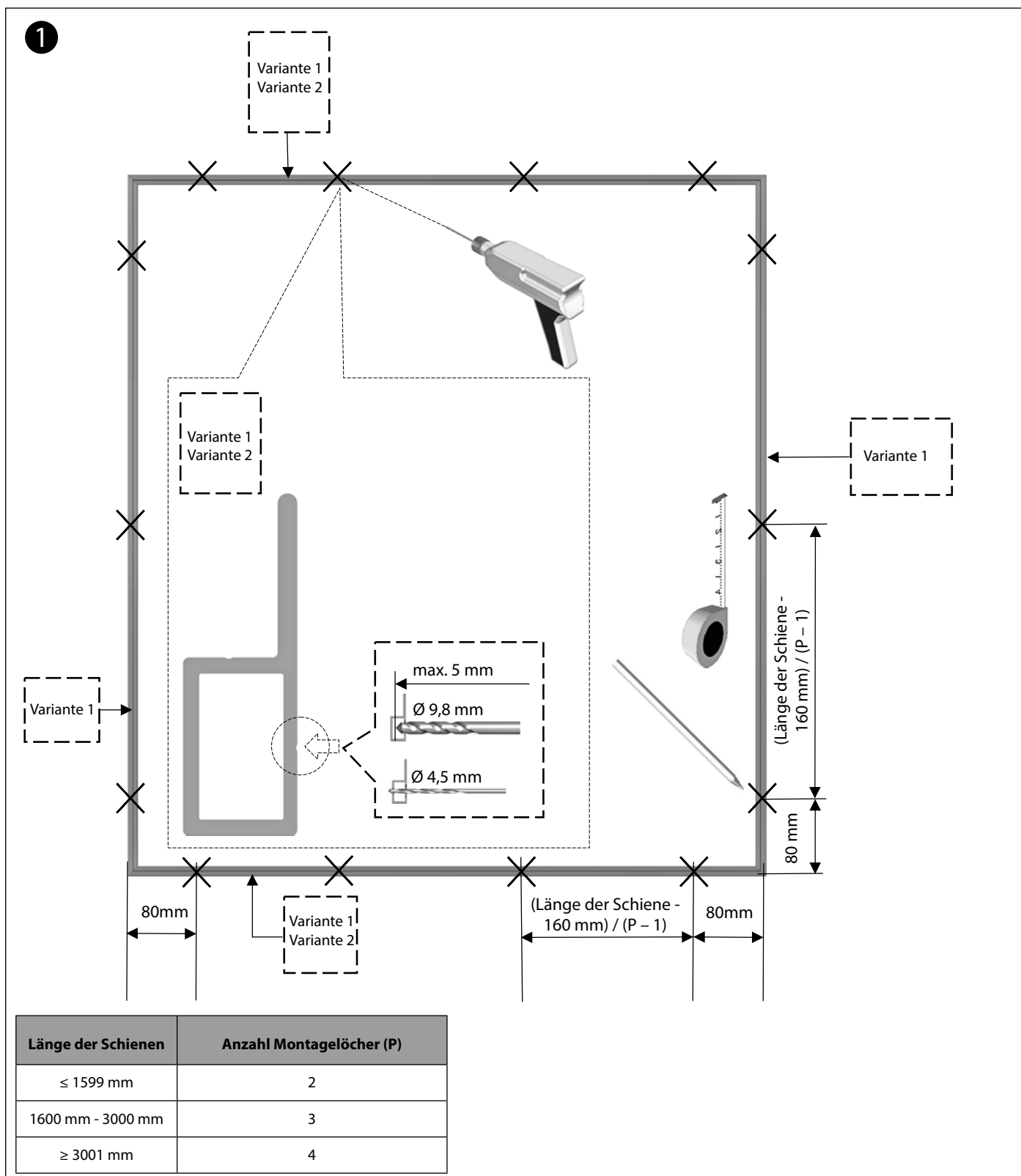

Beachten Sie, dass die Schienen ohne vorgebohrte Montagelöcher geliefert werden!

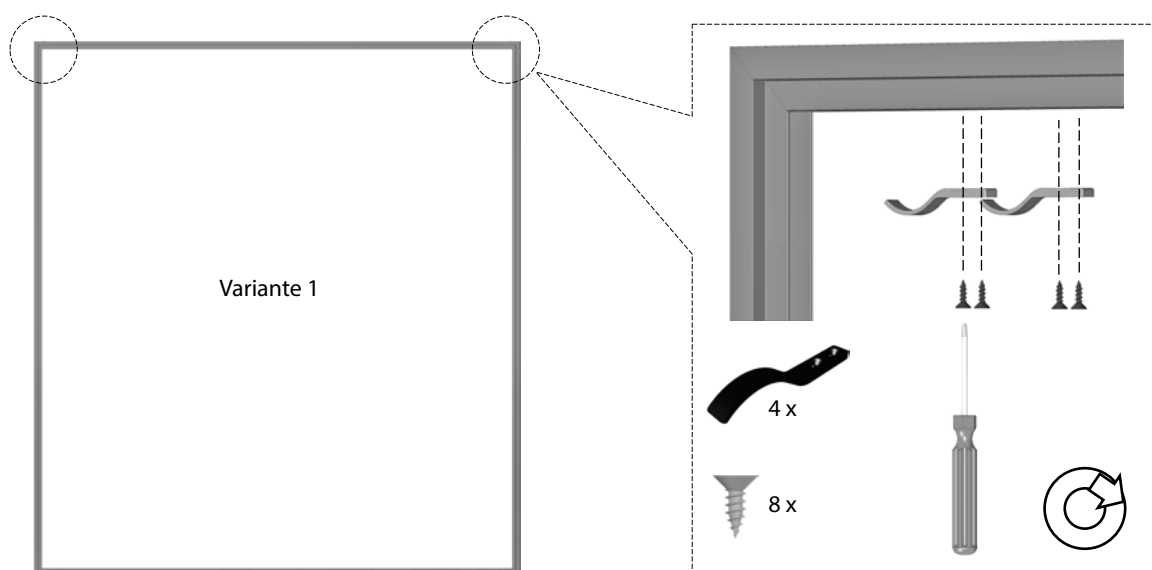
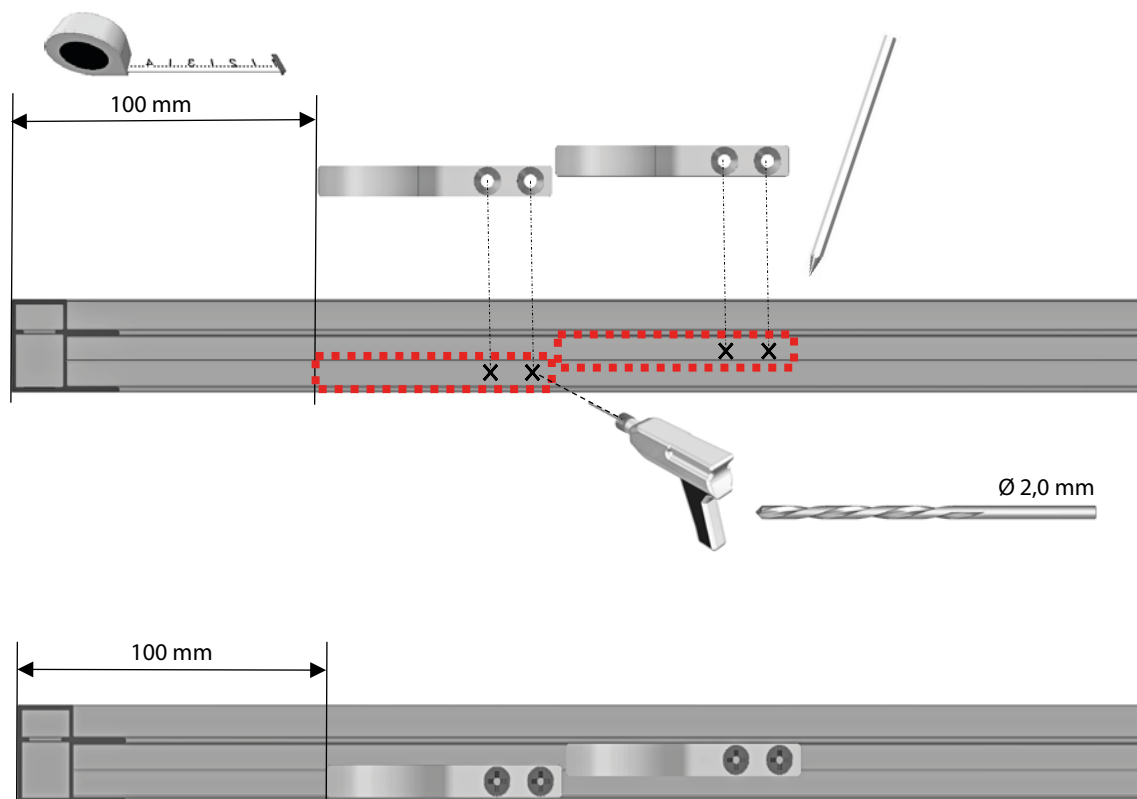
VORBEREITUNG DES MONTAGERAHMENS**MONTAGE B - DOPPELTÜR - VARIANTE 1 (OHNE VORGEBOHRTE MONTAGELÖCHER)****1**

VORBEREITUNG DES MONTAGERAHMENS

MONTAGE B - DOPPELTÜR - VARIANTE 2 (OHNE VORGEBOHRTE MONTAGELÖCHER)

1

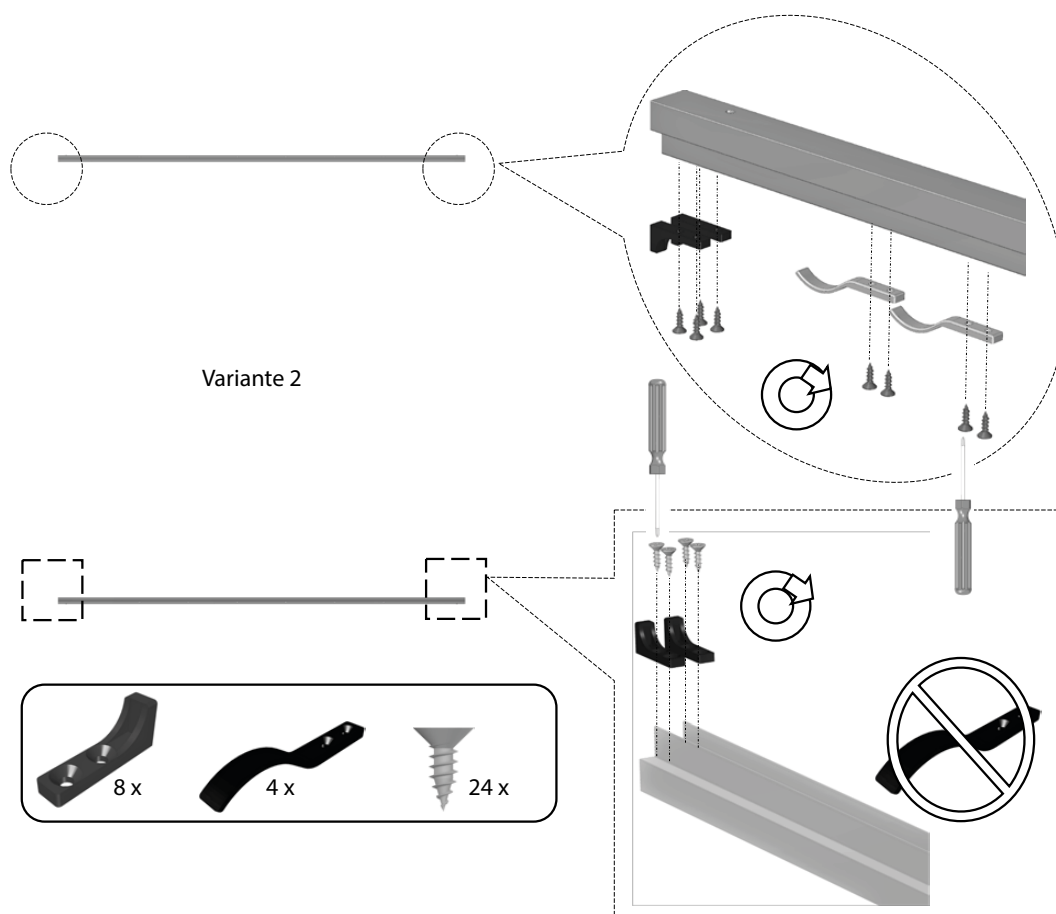
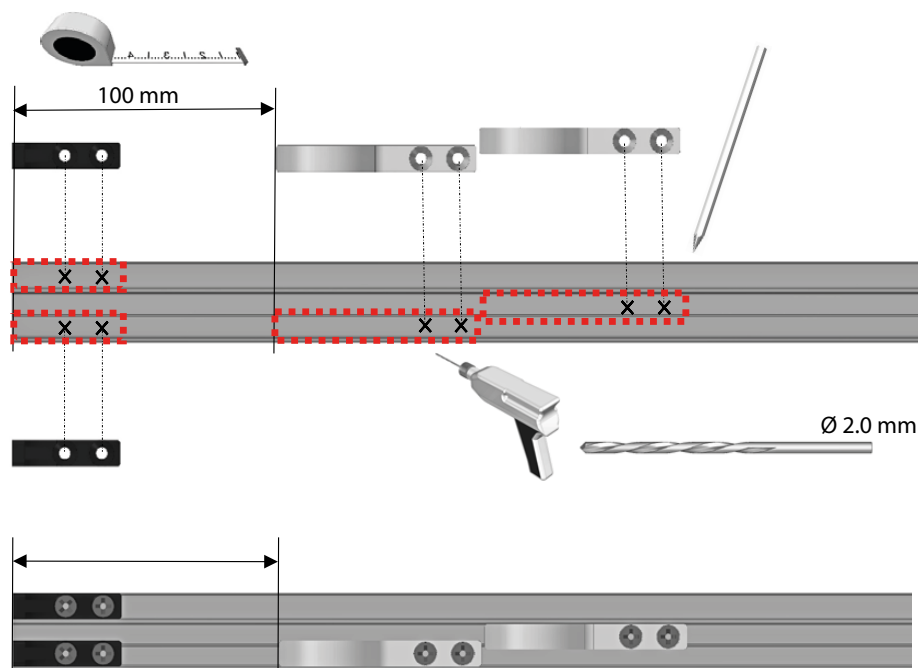



HERSTELLEN DER MONTAGELÖCHER IM MONTAGERAHMEN

MONTAGE B - DOPPELTÜR - VARIANTE 1 UND 2 (OHNE VORGEBOHRTE MONTAGELÖCHER)

1

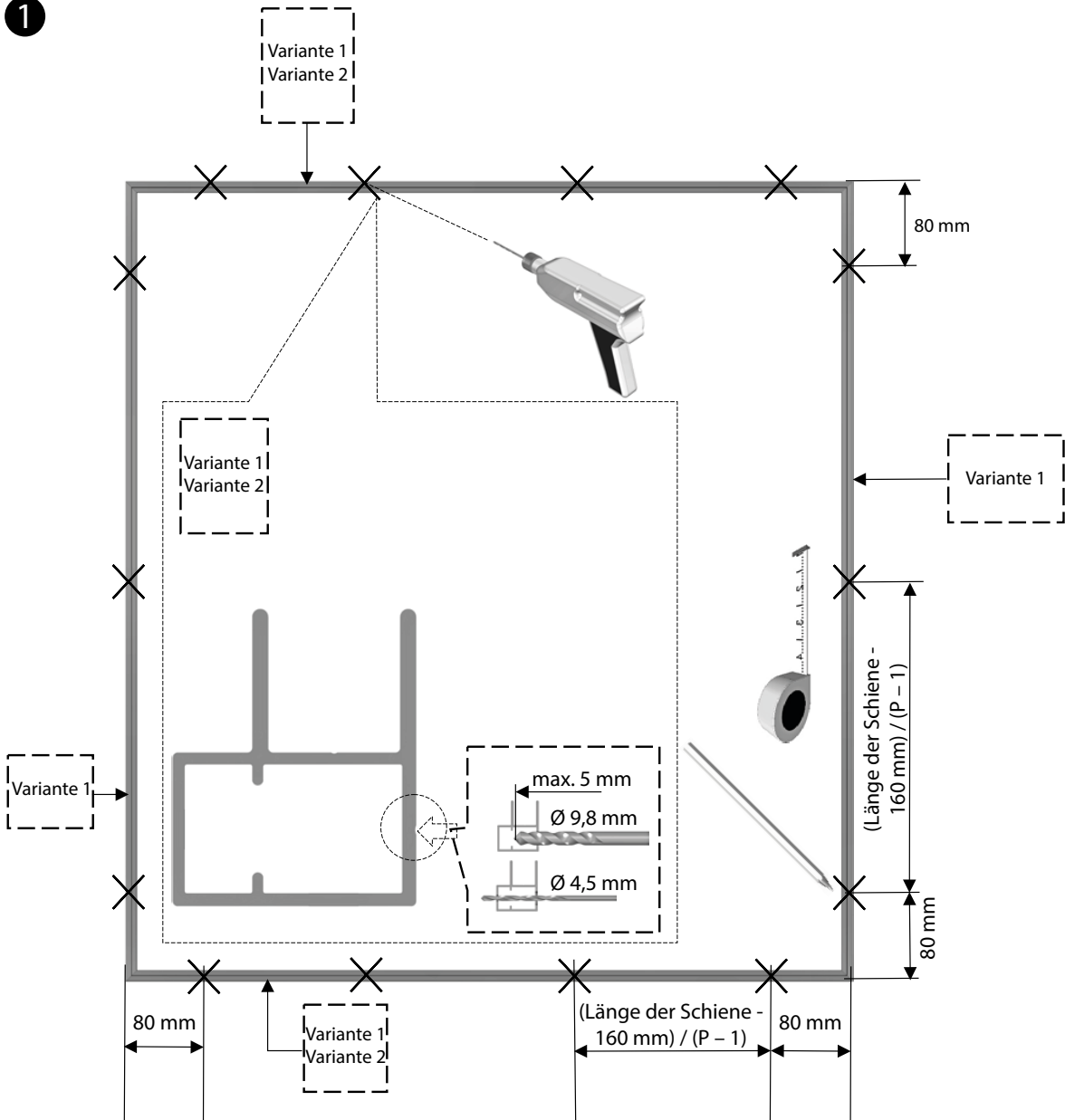

Länge der Schienen	Anzahl Montagelöcher (P)
≤ 1599 mm	2
1600 mm - 3000 mm	3
≥ 3001 mm	4

ZUSAMMENSETZEN DES MONTAGERAHMENS

MONTAGE A - EINFACHE TÜR - VARIANTE 1 / B - DOPPELTÜR - VARIANTE 1

1

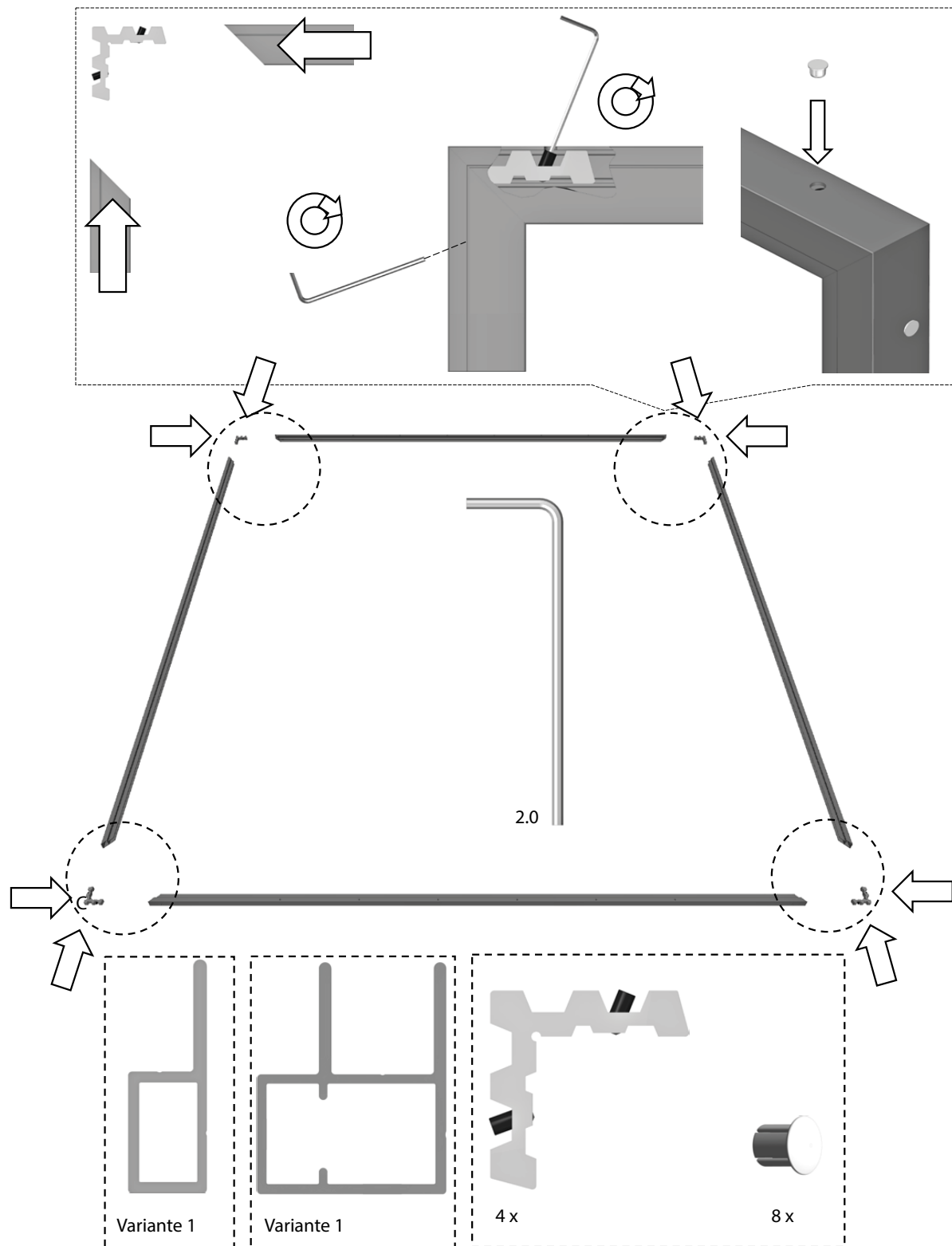

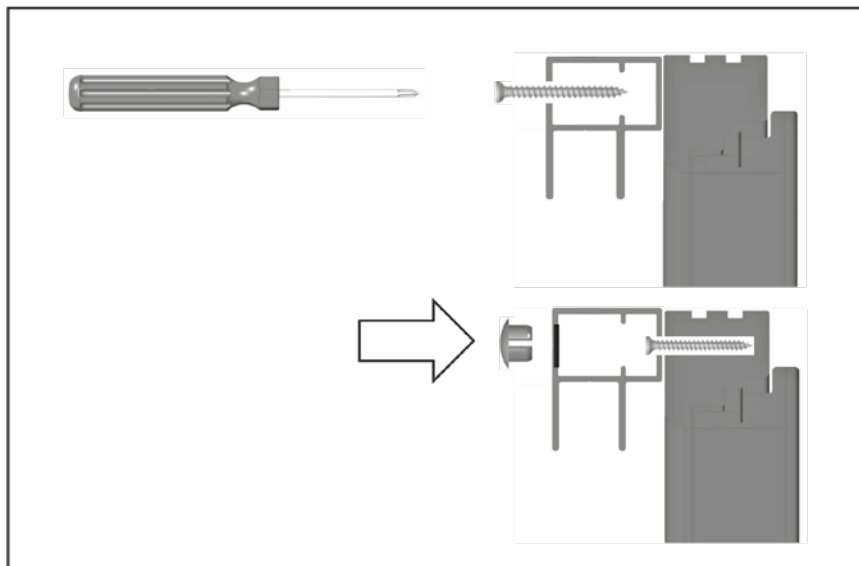
ANBRINGUNG DES MONTAGERAHMENS AUF DEN TÜRRAHMEN**1**

Achten Sie bei der Montage auf das Unergrundmaterial, aus dem Ihr Türrahmen besteht und auf dem sie Führungsschienen montiert werden.

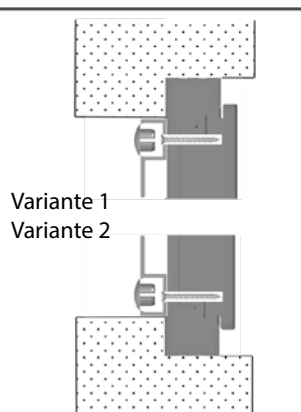
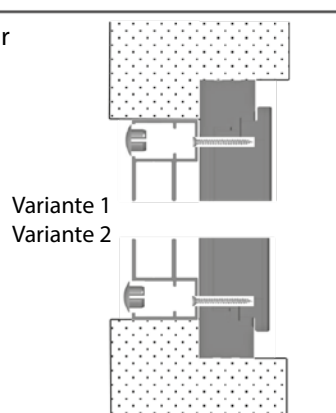
Montage A - einfache Tür**Montage B - einfache Tür**

2

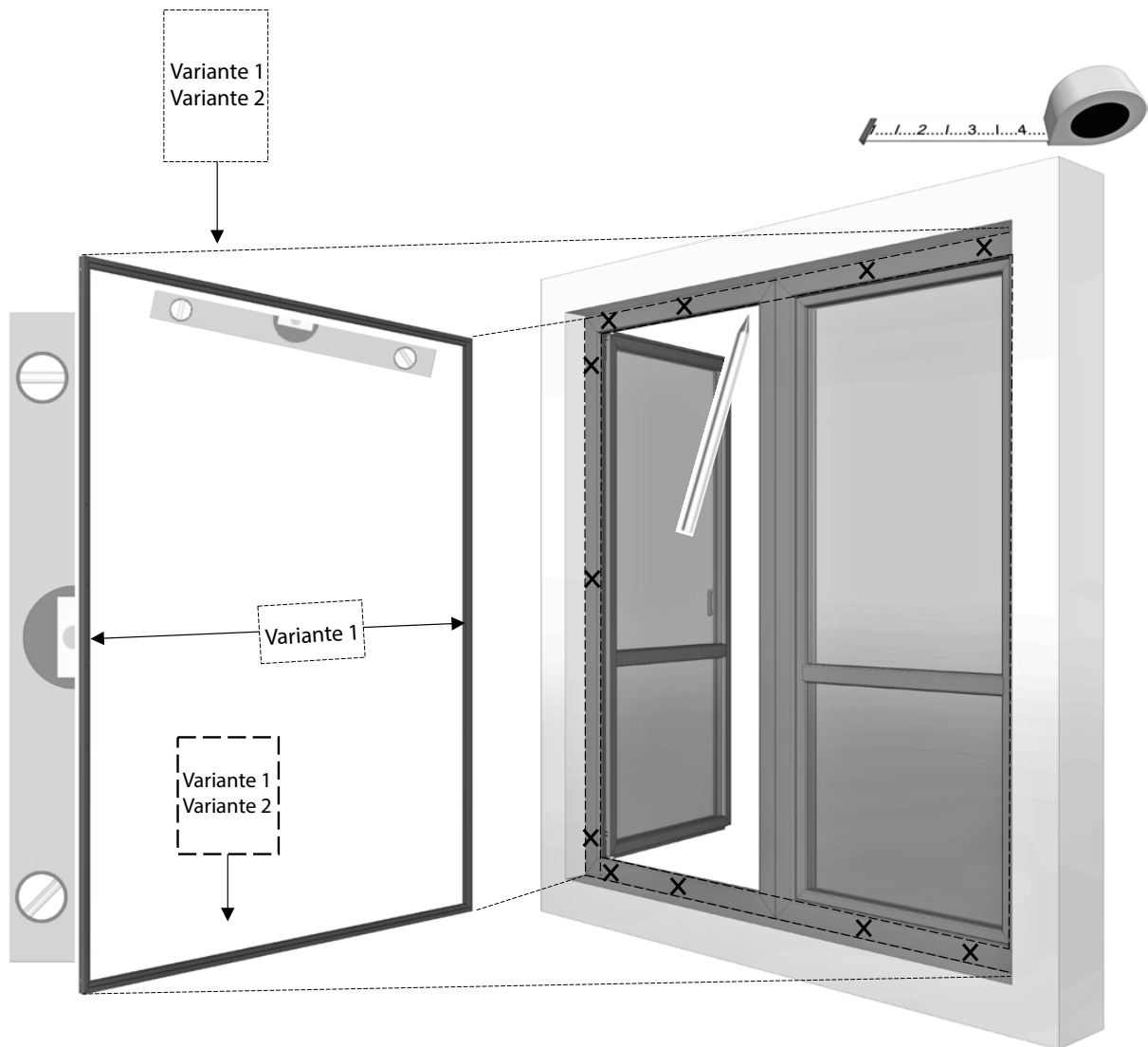

Zu besserer Hilfe, wird es empfohlen eine vorläufige Fixierung der Führungsschienen vorzunehmen, um die Abmessungen der Bohrungen genau auf Ihrem Türrahmen anzuzeichnen. Dies erleichtert Ihnen die Übertragung.



ZUSAMMENBAU DER SCHIEBETÜR

1

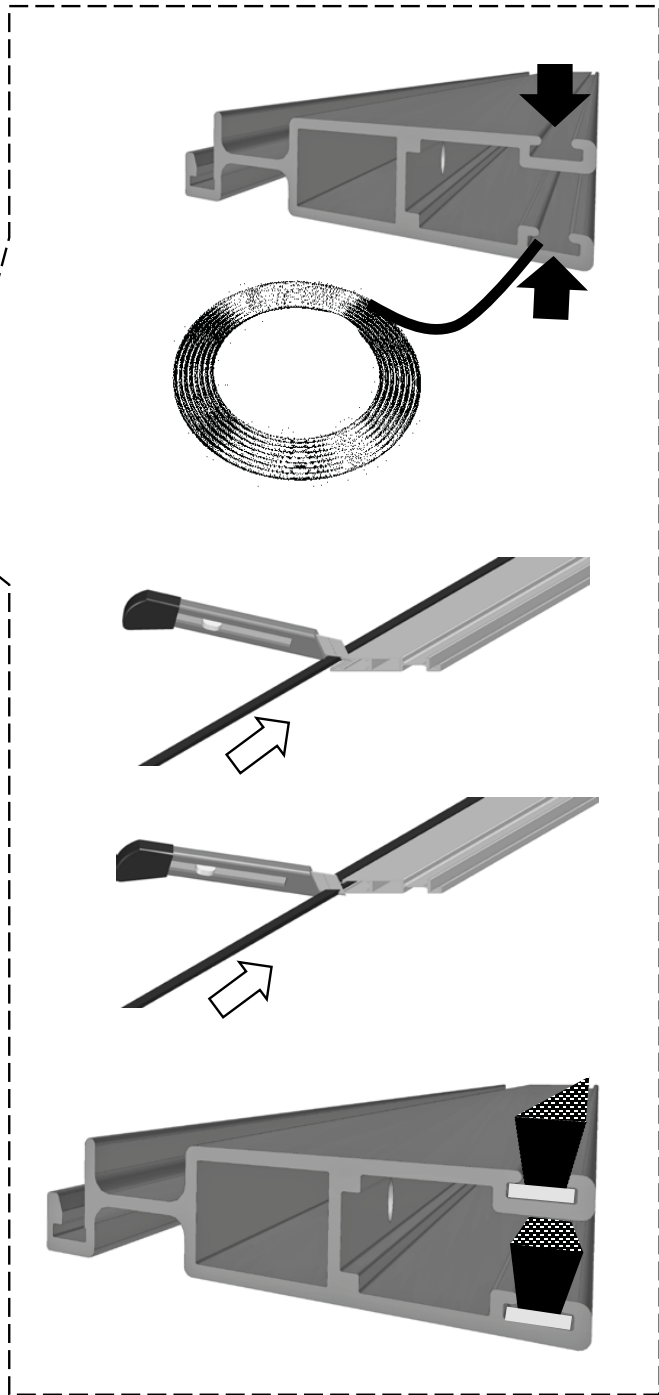
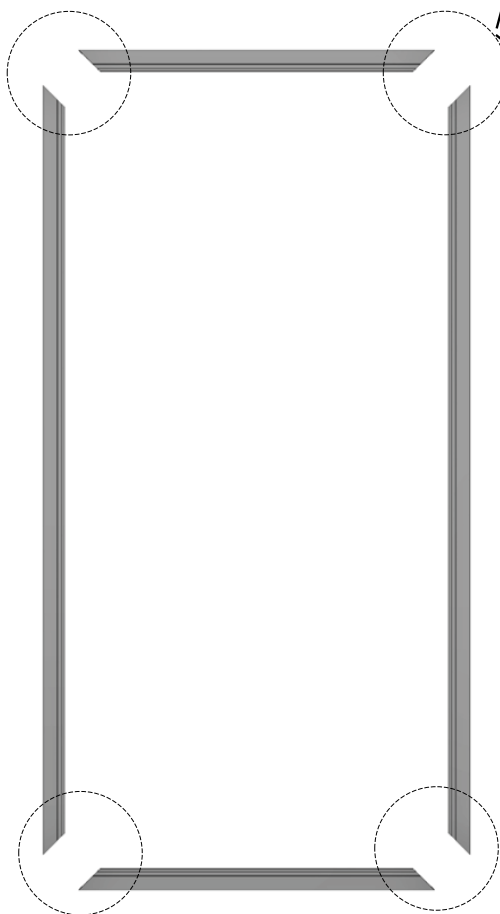

2

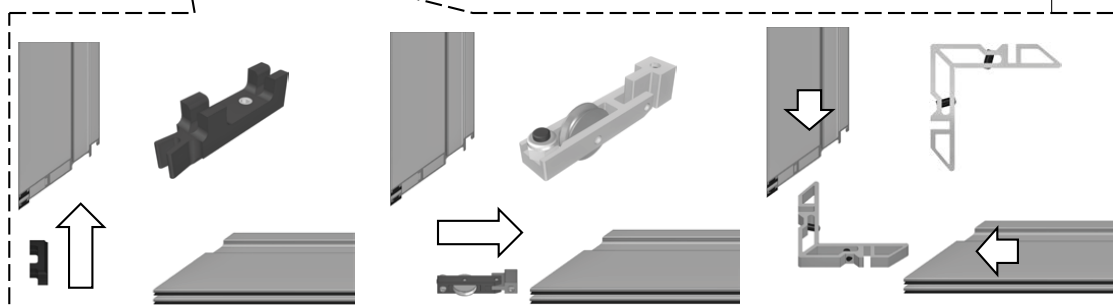
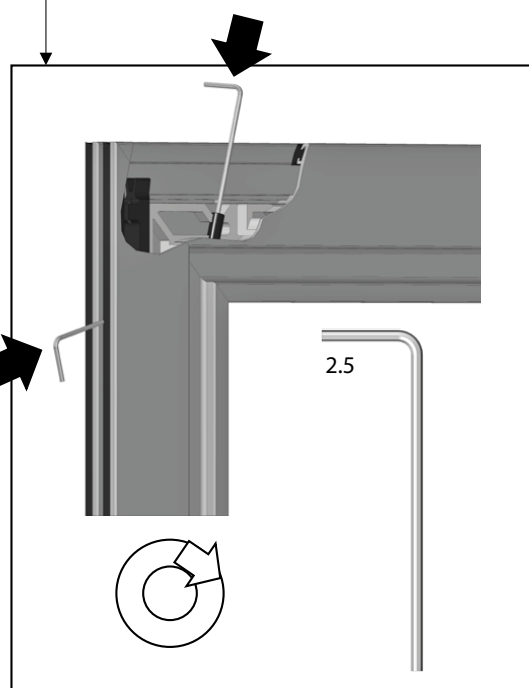
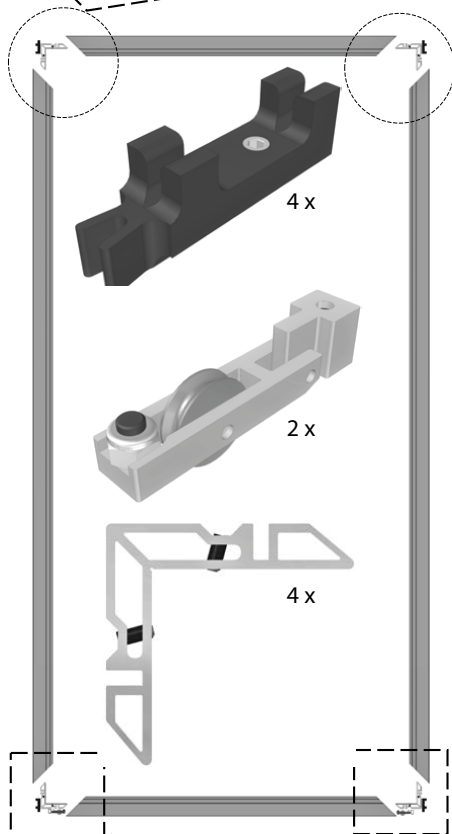
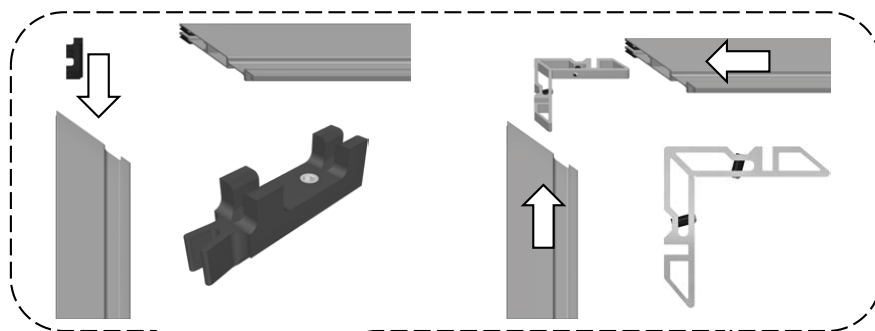



3

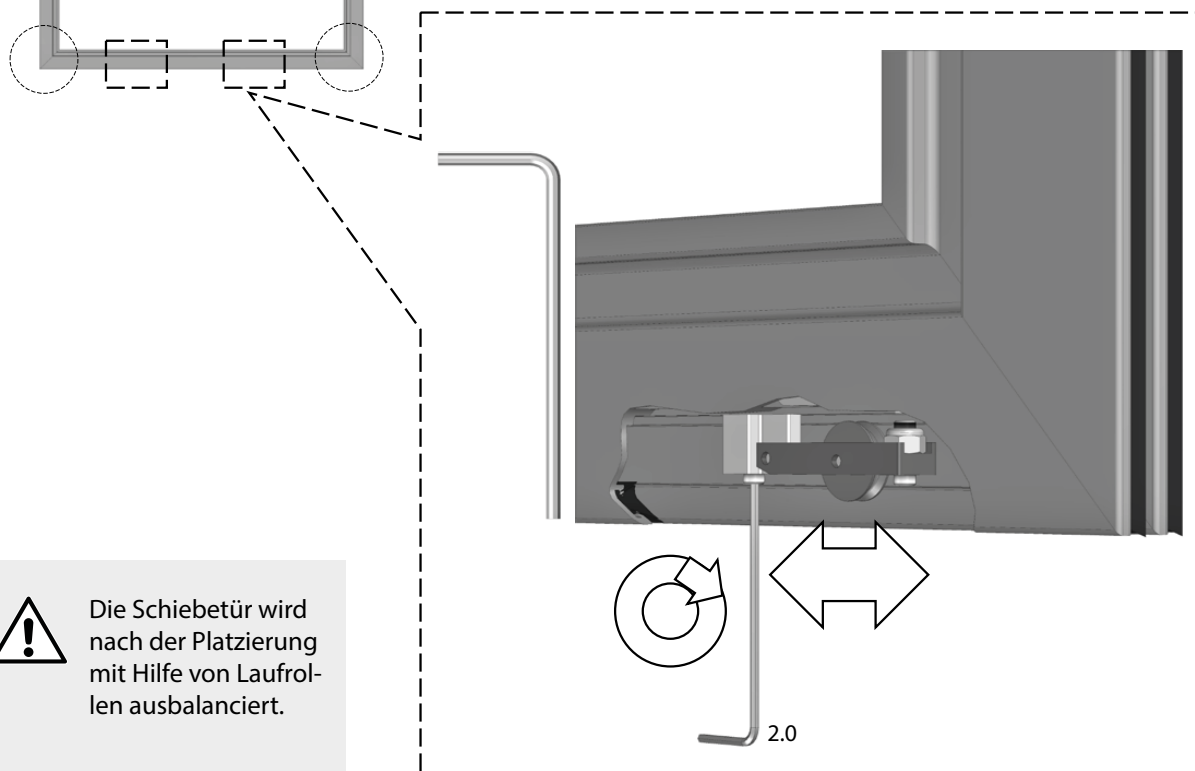
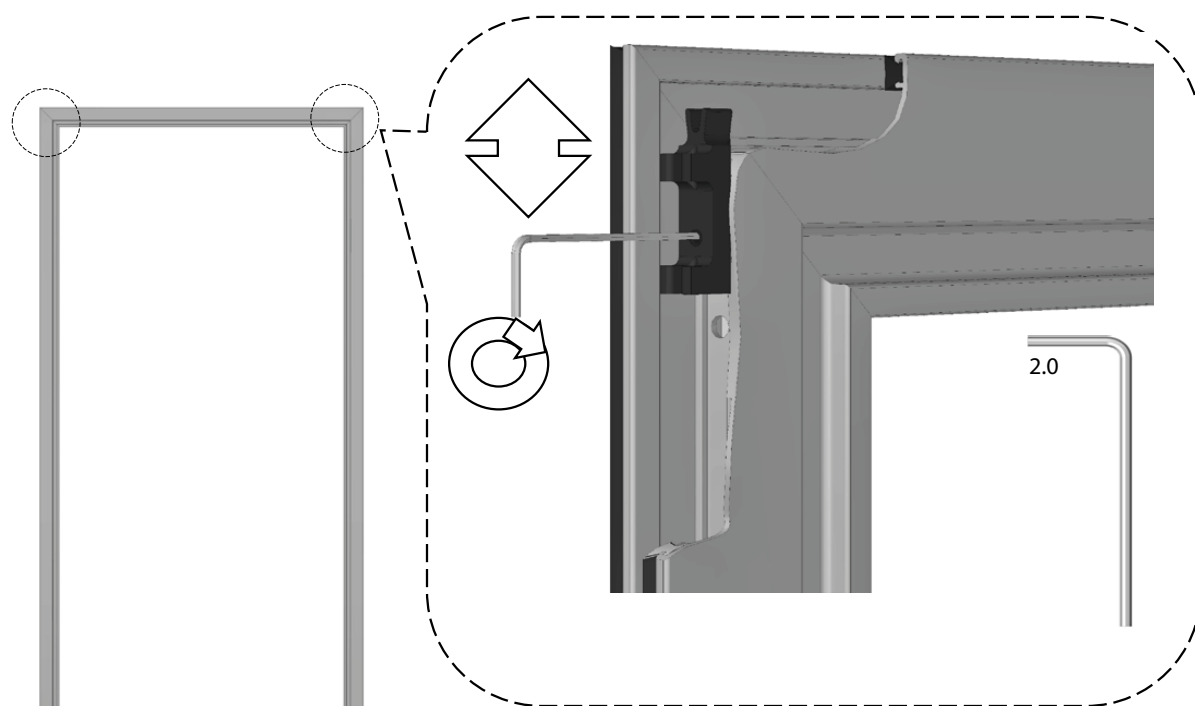

Die Schiebetür wird nach der Platzierung mit Hilfe von Laufrollen ausbalanciert.

4

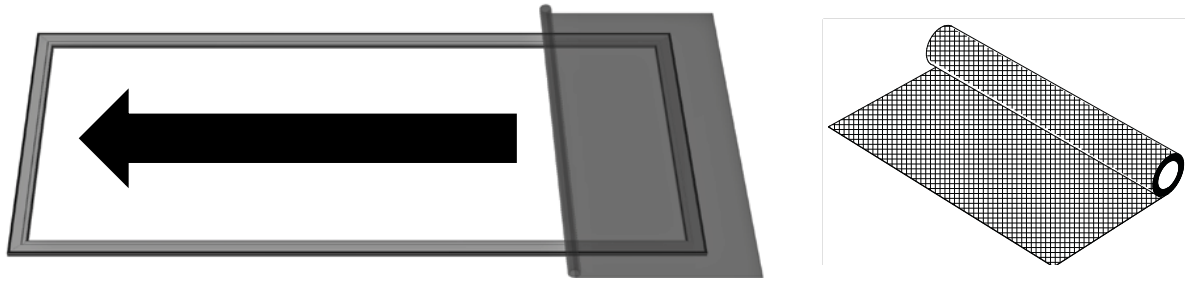

Das Moskitonetz sollte breiter und länger als der Innenrahmen der Schiebetür verlegt werden.

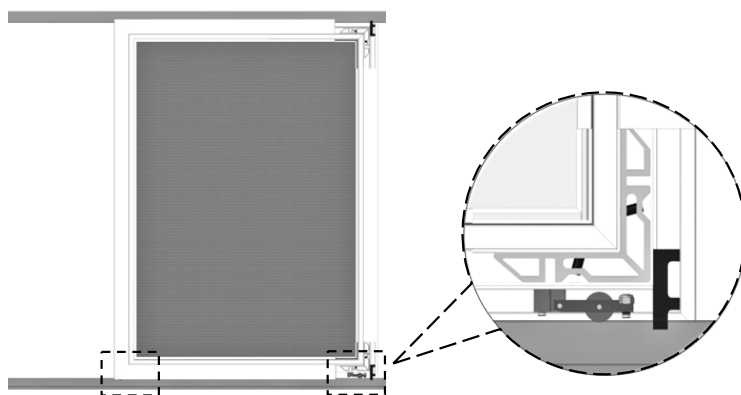
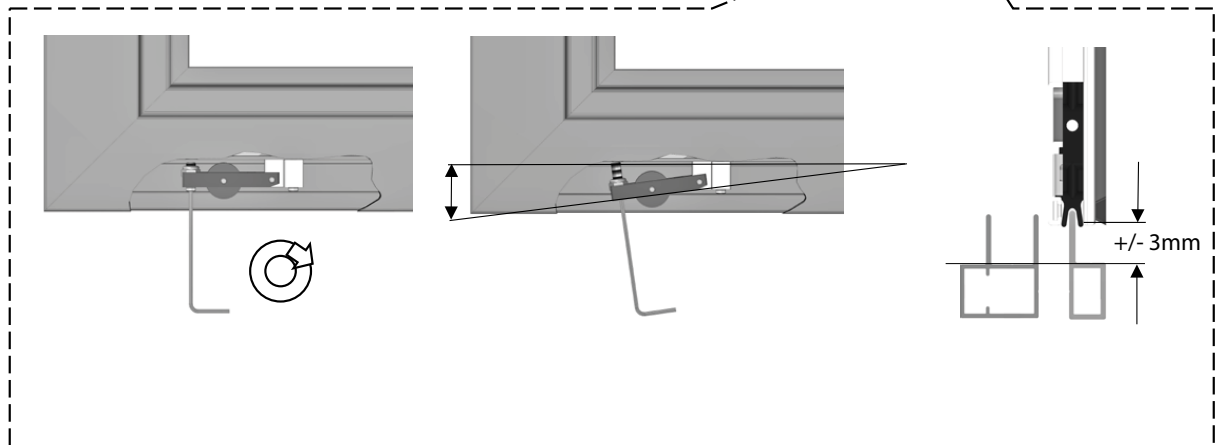
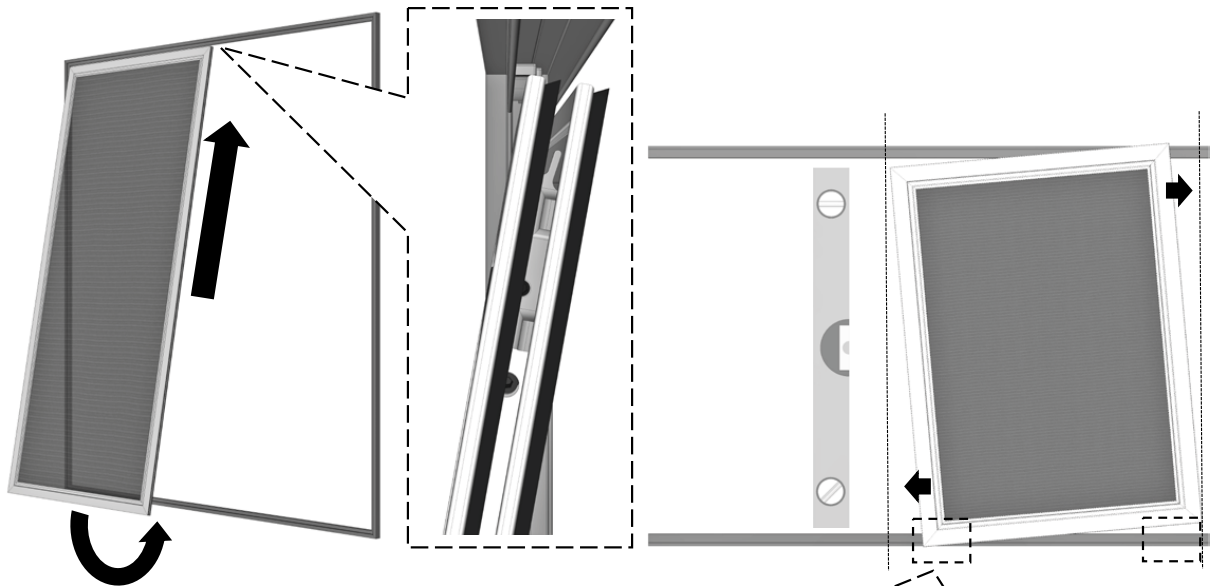

Das Insektenschutzgitter sollte an der Außenseite abgeschnitten werden. Achten Sie darauf, das Moskitonetz, die Dichtungen und Aluminiumprofile beim Schneiden des Netzes nicht zu beschädigen.

EINSETZEN DER SCHIEBETÜR IN DEN MONTAGERAHMEN**1**

Die Neigung der Insektenschutzschiebetür sollte angepasst werden, um die ordnungsgemäße Funktion und Dichtung des Moskitonetzes zu gewährleisten.

Die Einstellungen hierfür werden mit Schrauben in den Rollen vorgenommen.

2

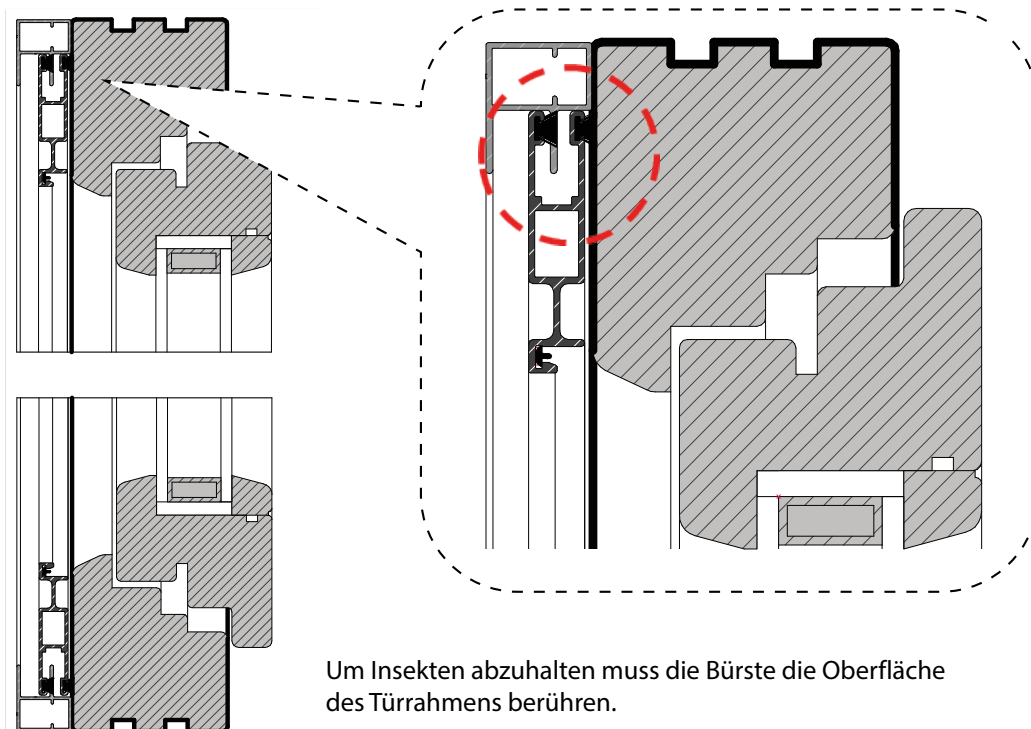
BEACHTEN SIE:

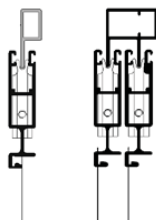
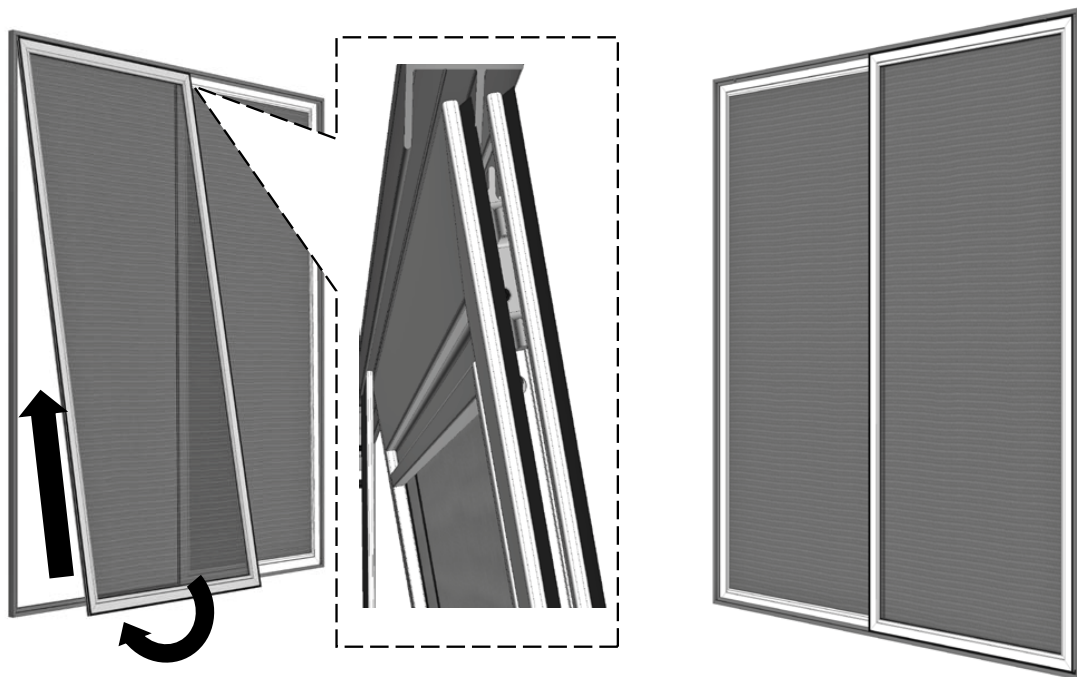
3

Achten Sie beim Einführen der Schiebetüren auf die richtige Positionierung in Bezug auf die untere Führungsschiene, um eine ordnungsgemäße Funktion und Dichtung zu gewährleisten.

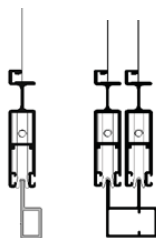
1**2**

Seitenansicht

1. Einfache Tür

2. Doppeltür

9



EU Waste and recycling / Registrations

Germany for packaging:

LUCID Reg.-no.: DE5768543732165

Austria for packaging:

Altstoff Recycling Austria (ARA) AG

ARA License number: 23363

France for packaging:

Citeo

Membership number / Take-back system: 532886

National registry: UIN FR208795_01SUIN

Spain for packaging:

Ecoembes

Membership number: 97556

JAROLIFT®™

ist eine eingetragene Marke der / is a registered trademark of Schoenberger Germany Enterprises GmbH & Co. KG
Zechstraße 1-7, 82069 Hohenschäftlarn

Tel.: 08178 / 932 932

Fax: 08178 / 932 970 20

info@jarolift.de

www.jarolift.de

Nachdruck, auch auszugsweise, nur mit Genehmigung des Verfassers.

Produktveränderungen, die aus unserer Sicht einer Qualitätsverbesserung dienen, können jederzeit, auch ohne Vorankündigung oder Mitteilung, durchgeführt werden.

Abbildungen können Beispielabbildungen sein, die im Erscheinungsbild von der gelieferten Ware abweichen.

Irrtümer vorbehalten. Für Druckfehler wird keine Haftung übernommen. Es gelten unsere allgemeinen Geschäftsbedingungen.

Eine aktuelle Version dieser Anleitung finden Sie auf
<http://www.jarolift.de/bedienungsanleitungen.html> /

Reprinting, even in extracts, only with permission of the author.

Product changes that serve to improve quality from our point of view can be made at any time, even without prior notice or notification.

Illustrations can be examples that deviate in appearance from the delivered goods.

Errors excepted. No liability is assumed for printing errors. Our general terms and conditions apply.

*A current version of these instructions can be found at
<http://www.jarolift.de/bedienungsanleitungen.html>*